



MODELS | SJ 7127 SJ 7135

Distributed By:



www.onesourcerental.com

MID SIZE SERIES Rough Terrain SCISSOR LIFTS

The Mid-Size Series Rough Terrain Scissor Lifts combine solid and powerful design elements to meet the demands of any job site environment. All models are equipped with Skyjack's unique axle based 4WD system which features a "Detroit Locker" type rear differential and limited slip front differential for unmatched terrainability.

Working heights for these two models are 33' (SJ 7127) and 41' (SJ 7135), while capacities are 1,500 lbs (SJ 7127) and 1,000 lbs (SJ 7135) respectively.

A standard 4.5' roll out extension deck adds to the already generous platform sizes, giving a combined 75 square feet of platform space. Both models are drivable at full height, and feature 30% gradeability.

Consistent with Skyjack's robust and reliable design features, the Mid Size Series Rough Terrain Scissor Lifts utilize Skyjack's standard color coded and numbered wiring system with analog based controls.

MID-SIZE SERIES

Rough Terrain Scissor Lifts

Specifications	SJ 7127	SJ 7135
A Work Height	33' (10.1 m)	41' (12.5 m)
B Raised Platform Height	27' (8.2 m)	35' (10.7 m)
C Lowered Platform Height	60.5" (1.5 m)	67.5" (1.7 m)
D Overall Width	71" (1.8 m)	71" (1.8 m)
E Overall Length	128" (3.3 m)	128" (3.3 m)
F Stowed Height (Rails Up)	105.5" (2.7 m)	112.5" (2.9 m)
G Stowed Height (Rails Down)	77" (2.0 m)	84" (2.1 m)
H Platform Width (Inside Dimension)	64" (1.6 m)	64" (1.6 m)
I Platform Length (Inside Dimension)	116.5" (3.0 m)	116.5" (3.0 m)
Deck Extension	4.5' (1.4 m)	4.5' (1.4 m)
Ground Clearance	8.5" (0.2 m)	8.5" (0.2 m)
Wheelbase	95" (2.4 m)	95" (2.4 m)
Weight	8,690 lbs (3,942 kg)	9,120 lbs (4,137 kg)
Gradeability	30%	30%
Turning Radius (Inside)	109" (2.8 m)	109" (2.8 m)
Turning Radius (Outside)	207" (5.3 m)	207" (5.3 m)
Lift Time (With Rated Load)	43 sec	41 sec
Drive Speed (Stowed)	3 mph (4.8 km/h)	3 mph (4.8 km/h)
Drive Speed (Raised)	0.35 mph (0.6 km/h)	0.35 mph (0.6 km/h)
Maximum Drive Height	Full Height	Full Height
Capacity (Overall)	1,500 lbs (680 kg)	1,000 lbs (454 kg)
Maximum # of Persons	5	4

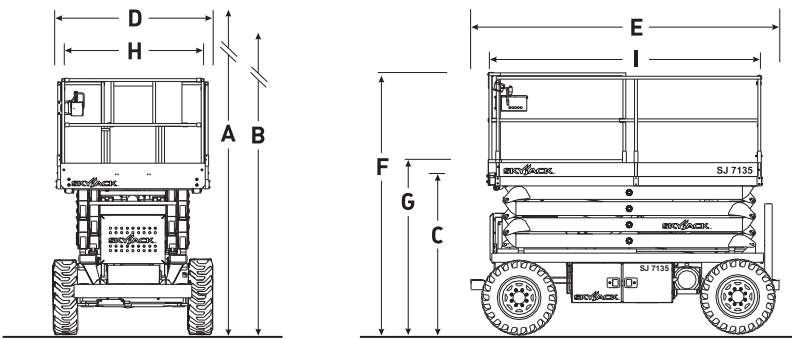

STANDARD FEATURES

- Drivable at full height
- Axle based 4WD
- "Detroit Locker" type rear differential and limited slip front differential
- Disc brake system on rear axle
- 4.5' (1.4 m) roll out extension deck
- 31hp Kubota Dual fuel (gas/propane) engine on roll out tray
- Analog control system
- Color coded and numbered wiring system
- 30% Gradeability
- Grip lug, air-filled tires
- 110V AC outlet on platform with GFI
- Tilt alarm with drive & lift cut-out
- All motion audible alarm
- Flashing light
- Operator horn
- Hinged railing system
- Full height spring hinged gate at rear
- Lanyard attachment points
- Tie down/lift lugs

OPTIONS†

- 4.5' (1.4 m) powered extension deck
 - 29hp Kubota Diesel engine (in lieu of std dual fuel)
 - Diesel engine with scrubber (in lieu of std dual fuel)
 - Independent/auto leveling outriggers
 - Shop airline to platform
 - 3500W hydraulic generator
 - Air-filled tires with tire sealant
 - Grip lug foam-filled tires
 - High flotation air-filled tires*
- *Reduces capacity to 900 lbs on 7135
- Non-marking grip lug air-filled tires
 - Non-marking grip lug foam-filled tires

† Capacities, and machine weights may differ when options are added

Skyjack Head Office

55 Campbell Rd. Guelph, ON Canada N1H 1B9
 Sales Inquiries: 1-877-755-4387 (1-877-SJLIFTS)
 Main Switchboard: 1-800-265-2738
 Phone: 519-837-0888
 Fax: 519-837-8104
 Email: skyjack@skyjack.com

www.skyjack.com

This brochure is for illustrative purpose only and based on the latest information at the time of printing. Skyjack Inc. reserves the right to make changes at any time, without notice, to specifications, standard and optional equipment. Consult the Operating Maintenance and Parts Manuals for proper procedures. Work platforms have been tested to comply with ANSI and CSA standards as interpreted by Skyjack, Inc.

Distributed By:

One Source
 RENTALS • SALES • SERVICE

www.onesourcerental.com

SKYJACK